



4D SYSTEMS

μLCD-144-G2(SGC) Serial LCD Display Module Data Sheet

Document Date: 19th April 2012
Document Revision: 1.0

Description



The **μLCD-144-G2(SGC)** is a compact and cost effective all in one 'SMART' serial display module using the latest state of the art TFT LCD technology with an embedded GOLDELOX-SGC graphics controller that delivers 'stand-alone' functionality to any project.

Powerful graphics, text, image, animation and countless more features are built inside the module. It offers a simple yet effective serial interface to any host micro-controller that can communicate via a serial port. All screen related functions are sent using a simple protocol via the serial interface.

The serial platform allows users to develop their application using their favourite micro-controller and software development tools. In short, the **μLCD-144-G2(SGC)** offers one of the most flexible embedded graphics solutions available.

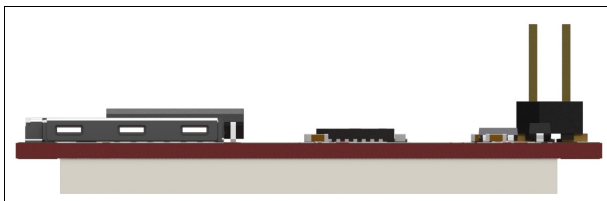

Features

- Low-cost LCD display graphics user interface solution.
- 128 x RGB x 128 resolution, 65K true to life colours, LCD TFT screen.
- 1.44" diagonal size, 43 x 31 x 6.4mm. Active Area: 25.5mm x 26.5mm.
- LED back lighting with greater than 150° viewing angle.
- Easy 10 pin interface to any external device: **3.3Vout, IO2, GND, IO1, RESET, GND, RX, TX, Vin, 5V OUT.**
- Serial TTL interface with auto-baud feature (300 to 256K baud).
- Powered by the 4D-Labs **GOLDELOX-SGC** processor (also available as separate OEM IC for volume users).
- On-board uSD/uSDHC memory card adaptor for storing of icons, images, animations, etc. Supports 64Mb to 2Gig micro-SD as well as micro-SDHC memory cards (4GB and above).
- Comprehensive set of built in high level graphics functions and algorithms that can draw lines, circles, text, and much more.
- Display full colour images, animations, icons and video clips.
- Supports all available Windows fonts and characters (imported as external fonts).
- Multiple switch/button feature on a single pin.
- Dedicated sound pin with complex sound generation.
- 4.0V to 5.5V range operation (single supply).
- RoHS Compliant.

Applications

- Elevator control systems.
- Point of sale terminals.
- Electronic gauges and metres.
- Test and measurement
- General purpose instrumentation.
- Industrial control
- Automotive
- Medical applications.
- Home appliances
- Security and gaming equipment.
- General purposes embedded applications.
- GPS Applications
- Advertising

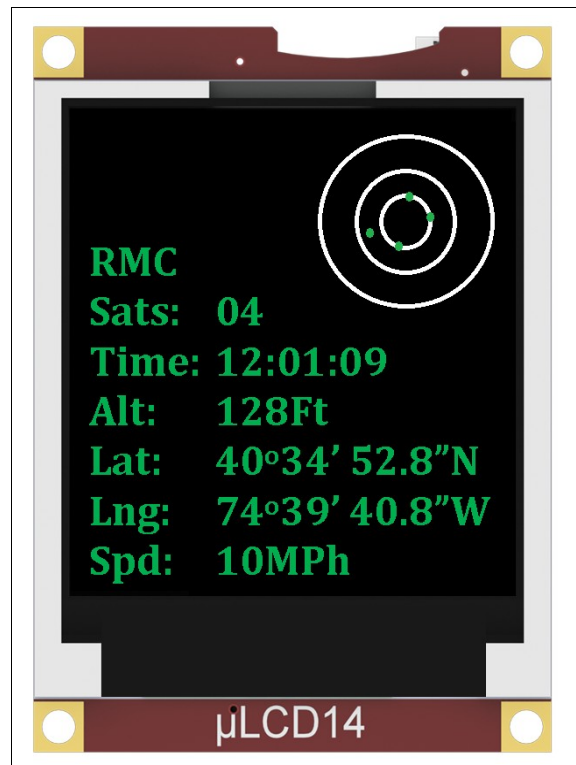

Table of Contents

1. Pin Configuration and Summary.....	5
2. Hardware Interface - Pins.....	6
2.1 Serial Interface - UART	6
2.2 Button-Switch Interface.....	6
2.3 Sound Interface.....	7
2.4 System Pins.....	7
3. Software Interface - Commands.....	8
4. Module Features.....	9
4.1 The Display – 1.44” TFT LCD.....	9
4.2 The GOLDELOX-SGC Processor.....	9
4.3 The uSD/uSDHC Memory Card.....	10
5. Power-Up and Reset.....	10
5.1 Splash Screen on Power-Up.....	11
5.2 4DSL Memory Card Script Program	11
5.3 Auto-Run Card Script Program	11
6. Programming - System Updates.....	11
7. LCD Screen Precautions.....	12
8. Mechanical Dimensions.....	13
9. Development and Support Tools.....	14
9.1 PmmC Loader – Software Programming Tool	14
9.2 microUSB – Hardware Programming Tool.....	14
9.3 Display Initialisation Setup Personality (DISP) – Software Programming Tool.....	14
9.4 FONT Tool – Software Tool.....	14
9.5 Graphics Composer – Software Tool.....	15
9.6 FAT Controller – Software Test Tool.....	15
10. Reference Design.....	16
11. Specifications and Ratings.....	17
Proprietary Information.....	19
Disclaimer of Warranties & Limitation of Liability.....	19

1. Pin Configuration and Summary



Pin	Symbol	I/O	Description
1	+5V	I	Main Voltage Supply +ve input pin. Reverse polarity protected. Range is 4.0V to 5.5V, nominal 5.0V.
2	5V OUT	P	The label “5V IN” on the PCB is an error. It is 5V OUT. “5V OUT” provides (“+5V” - 0.3V) ~ 4.7 V through the protection diode.
3	TX	O	Asynchronous Serial Transmit pin. Output data is at TTL voltage levels. Connect this pin to external device Serial Receive (Rx) signal. This pin is tolerant up to 5.0V levels.
4	IO2	O	SOUND. See section 2.3 for more detail.
5	RX	I	Asynchronous Serial Receive pin. Connect this pin to external device Serial Transmit (Tx) signal. This pin is tolerant up to 5.0V levels.
6	IO1	I	SWITCH. See section 2.2 for more detail.
7	GND	P	Supply Ground.
8	GND	P	Supply Ground.
9	RESET	I	Master Reset signal. Internally pulled up to 3.3V via a 4.7K resistor. An active Low pulse greater than 2 micro-seconds will reset the module. If the module needs to be reset externally, only use open collector type circuits. This pin is not driven low by any internal conditions. The host should control this pin via one of its port pins using an open collector/drain arrangement.
10	3.3V	P	3.3V regulated output. Available current up to 50ma to power external circuitry.

2. Hardware Interface - Pins

The µLCD-144-G2(SGC) provides both a hardware and a software interface. This section describes in detail the hardware interface pins.

2.1 Serial Interface - UART

The µLCD-144-G2(SGC) has a dedicated hardware UART that can communicate with a host micro-controller via its serial port. This is the main interface used by the host micro-controller to communicate with the µLCD module to send commands and receive back data. The primary features are:

- Full-Duplex 8 bit data transmission and reception through the TX and RX pins.
- Data format: 8 bits, No Parity, 1 Stop bit.
- Auto Baud feature.
- Baud rates from 300 baud up to 256K baud.

A single byte serial transmission consists of the start bit, 8-bits of data followed by the stop bit. The start bit is always 0, while a stop bit is always 1. The LSB (Least Significant Bit, Bit 0) is sent out first following the start bit. Figure below shows a single byte transmission timing diagram.

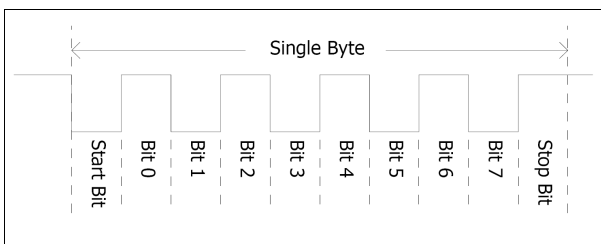

The Serial port is also the primary interface for updating and programming the on board GOLDELOX-SGC processor with future serial command upgrades and enhancements. Please refer to **Section 6. Programming-System Updates** for more details.

TX pin 3 (Serial Transmit):

Asynchronous Serial port Transmit pin, TX. Connect this pin to host micro-controller Serial Receive (Rx) signal. The host receives data from the µLCD module via this pin.

RX pin 5 (Serial Receive):

Asynchronous Serial port Receive pin, RX. Connect this pin to host micro-controller Serial Transmit (Tx) signal. The host transmits data to the µLCD module via this pin.

2.2 Button-Switch Interface

Multiple Buttons can be connected to a single pin on the µLCD module. Up to 5 buttons or a 5 position multi switch connects to a junction of a resistor ladder network that forms a voltage divider. The SWITCH pin internally reads the analogue value and decodes it accordingly.

SWITCH pin 6 (Multiple Button Input):

Connect up to 5 push buttons or a 5 position multi-switch as shown in the diagram below. Each consecutive button must be connected to ground via its matching resistor.

Unused buttons do not need resistors to be connected to the circuit. Table below lists the buttons and corresponding resistor values. If no buttons or switches are used then connect this pin to GND.

Number of Buttons	Button Number	Resistor Value
1	SW1	22K
2	SW2	10K
3	SW3	4.7K
4	SW4	2.2K
5	SW5	1.2K

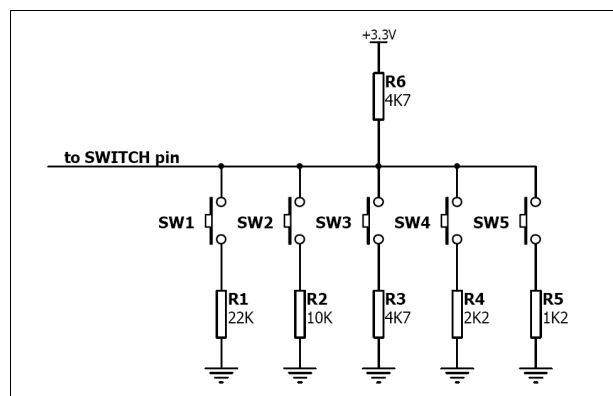

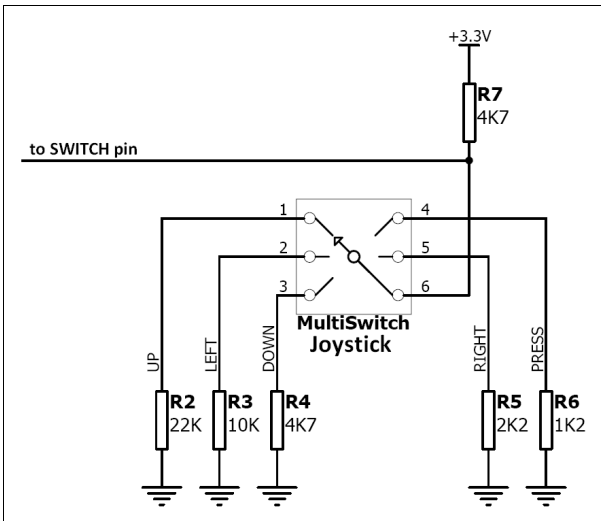

Note: If this pin is connected to GND on power-up, it will auto-run a script program from the memory card.

2.3 Sound Interface

The µLCD module is capable of generating complex sounds and audio from its SOUND pin. A simple speaker circuit as shown below can be utilised. For a complete list of sound commands please refer to the separate document titled '*GOLDELOX-SGC-COMMANDS-SIS.pdf*'.

SOUND pin 4 (Sound-Audio Output):

Sound and audio waveforms are generated from this pin. Connect this pin to a simple speaker circuit detailed above. If unused then this pin must be left open or floating.

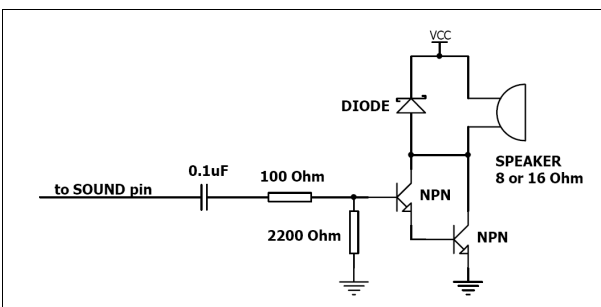

2.4 System Pins

+5V pin 1 (Module Supply Voltage Input):

Module supply voltage input pin. This pin must be connected to a regulated supply voltage in the range of 4.0 Volts to 5.5 Volts DC. Nominal operating voltage is 5.0 Volts.

5V OUT pin 2 (~ 4.7V Output):

External circuitry that requires approximately 5V supply can be powered up via this pin. Maximum available current is 50mA.

Note: Pin 2 is labelled “5V IN” by mistake. It is 5V OUT. This pin provides (“+5V” - 0.3V) ~ 4.7 V through the protection diode.

3.3Vout pin 10 (3.3V Regulated Output):

External circuitry that requires a regulated 3.3V supply can be powered up via this pin. Maximum available current is 50mA.

GND pins 7,8 (Module Ground):

Module ground pins. These pins must be connected to ground.

RESET pin 9 (Module Master Reset):

Module Master Reset pin. An active low pulse of greater than 2 micro-seconds will reset the module. Internally pulled up to 3.3V via 4.7K resistor. Only use open collector type circuits to reset the device if an external reset is required.

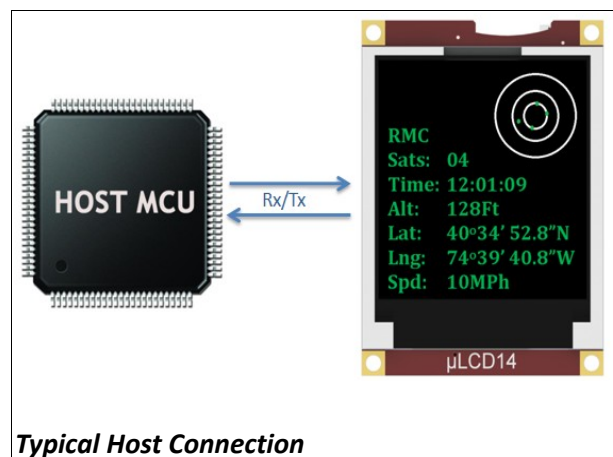

Typical Host Connection

3. Software Interface - Commands

The software interface provided by the μLCD-144-G2(SGC) module is a set of easy to use serial commands. The command set is grouped into following sections:

General Commands:

- AutoBaud
- Version-Device Info Request
- Replace Background Colour
- Clear Screen
- Display Control Functions
- Sleep
- Switch-Buttons-Joystick Status
- Wait for Switch-Buttons-Joystick Status
- Sound
- Tune

Graphics Commands:

- Add User Bitmap Character
- Draw User Bitmap Character
- Draw Circle
- Draw Triangle
- Draw Image-Icon
- Set Background Color
- Draw Line
- Draw Pixel
- Read Pixel
- Screen Copy-Paste
- Draw Polygon
- Replace Colour
- Set Pen Size
- Draw Rectangle

Text Commands:

- Set Font
- Set Transparent-Opaque Text
- Draw "String" Text (graphics format)
- Draw ASCII Char (text format)
- Draw Text Button
- Draw "String" Text (text format)
- Draw ASCII Char (graphics format)

uSD/uSDHC Memory Card Commands:

- Set Address Pointer of Card
- Screen Copy-Save to Card
- Display Image-Icon from Card

- Display Object from Card
- Run Script (4DSL) Program from Card
- Read Sector Block from Card
- Display Video-Animation Clip
- Write Sector Block to Card
- Initialise Memory Card
- Read Byte Data from Card
- Write Byte Data to Card

4DSL - Scripting Language Commands:

- Delay
- Set Counter
- Decrement Counter
- Jump to Address If Counter Not Zero
- Jump to Address
- Exit-Terminate Script Program

For a complete detailed list of commands refer to the separate document titled:

"GOLDELOX-SGC-COMMANDS-SIS.pdf"

The Each command is made up of a sequence of data bytes. When a command is sent to the module and the operation is completed, the module will always return a response. For a command that has no specific response the module will send back a single acknowledge byte called the ACK (06hex), in the case of success, or NAK (15hex), in the case of failure.

Commands having specific responses may send back varying numbers of bytes, depending upon the command and response. It will take the module a certain amount of time to respond, depending on the command type and the operation that has to be performed. If the μLCD receives a command that it does not understand it will reply back with a negative acknowledge called the **NAK** (15hex). Since a command is only identified by its *position* in the sequence of data bytes sending incorrect data can result in wildly incorrect operation.

4. Module Features

The µLCD-144-G2(SGC) module is equipped to accommodate most applications. Some of the main features of the module are listed below.

4.1 The Display – 1.44” TFT LCD

The µLCD-144-G2(SGC) is equipped with a full colour LCD screen. Some of the features of the screen are:

- Screen Size: 1.44” diagonal
- Screen Dimensions: 33.5 x 37.5mm.
- Viewing Area: 25.5 x 26.5mm
- 65K true to life colours
- Luminance: 250 cd/m2
- Contrast Ratio: 450
- Viewing Angle: greater than 150 degrees
- LED Back lighting

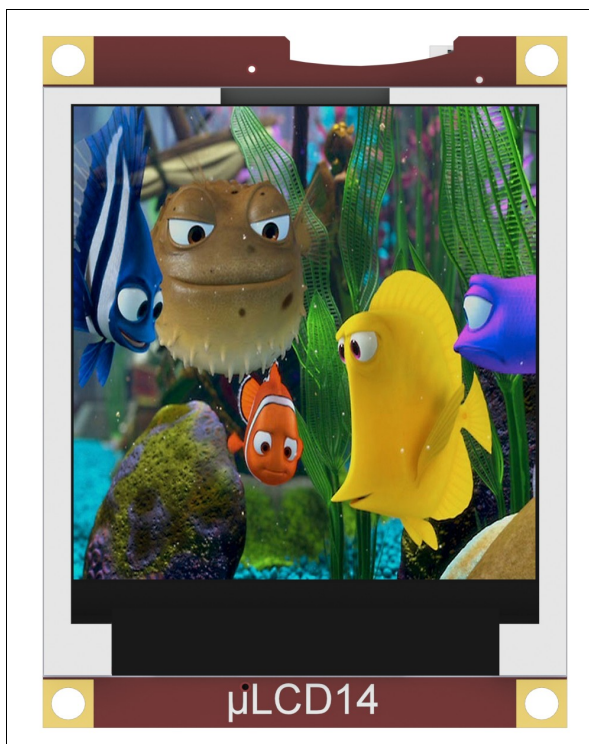

4.2 The GOLDELOX-SGC Processor

The module is designed around the GOLDELOX-SGC Serial Graphics Controller from 4D-Labs.



The **GOLDELOX-SGC** is an intelligent Serial Graphics Controller and the interface to the LCD display is almost plug-n-play. All of the data and control signals are provided by the chip to interface directly to the display.

Powerful graphics, text, image, animation and countless more features are built right inside the chip. It offers a simple yet effective serial interface to any host micro-controller that can communicate via a serial port.

The data sheet for the chip is available from the www.4dsystems.com.au website:
"GOLDELOX-SGC-DS-revx.pdf"

4.3 The uSD/uSDHC Memory Card

The module supports micro-SD/SDHC memory cards via the on-board uSD connector. The memory card is used for all multimedia file retrieval such as images, animations and movie clips. The memory card can also be used as general purpose storage for data logging applications. Support is available for uSD with up to 2GB capacity and for high capacity HC memory cards starting from 4GB and above.

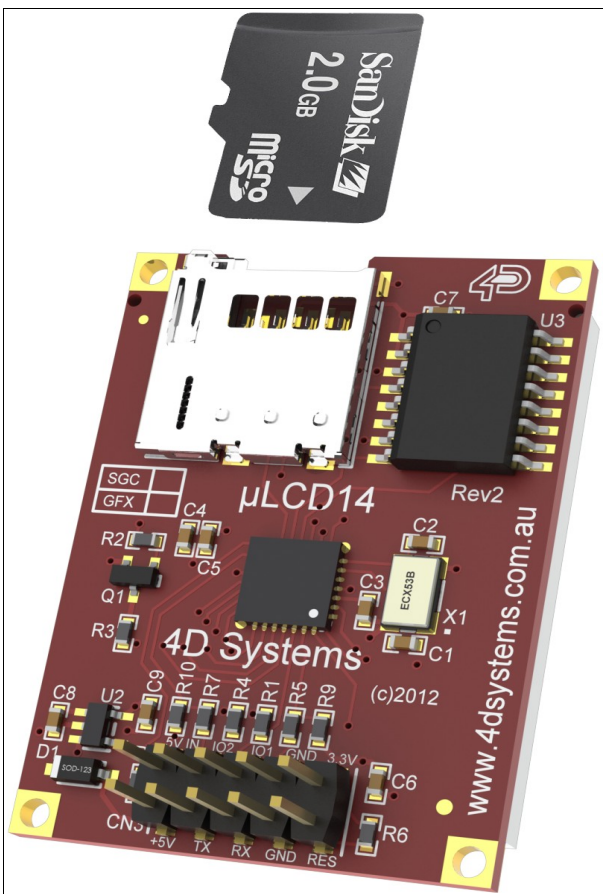

5. Power-Up and Reset

When the μLCD module comes out of a power up or external reset, a sequence of events must be observed before attempting to communicate with the module:

- Allow up to 500ms delay after power-up or reset for the module to settle without a uSD card inserted. If a uSD card is inserted the initialization time of the particular card will need to be added, better quality cards tend to initialize in about 75ms or quicker, lower quality ones can take up to a second. Do not attempt to communicate with the module during this period. The module may send garbage on its TX Data line during this period, the host should disable its Rx Data reception.
- Within 100ms of powering up, the host should make sure it has its Tx line pulled HIGH. If the host Tx (μLCD RX) is LOW or floating after the 100ms period, the module may misinterpret this as the START bit of the auto-baud character and lock onto some undesired baud rate.
- The host transmits the auto-baud character (capital **U**, 55hex) as the first command so the module can lock onto the host's baud rate.

Once the host receives the ACK, the μLCD module is now ready to accept commands.

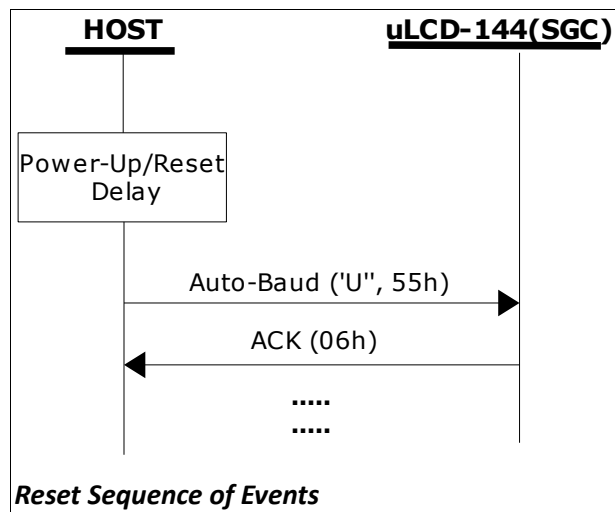

5.1 Splash Screen on Power-Up

The μLCD-144-G2(SGC) will wait up to 5 seconds with its screen blank for the host to transmit the Auto-Baud command ('U', 55hex). If the host has not transmitted the Auto-Baud command by the end of this period the module will display a built-in splash screen. If the host has transmitted the Auto-Baud command, the screen will remain blank. This wait period is for those customer specific applications where the splash screen is undesired.

5.2 4DSL Memory Card Script Program

The complete command summary for the GOLDELOX-SGC is listed in the previous section 3 of this document. The command execution is not only limited to the host sending these via the serial interface. The majority of them can be composed as a script and written into memory card. A 4DSL script program is a sequence of those commands that reside and can be executed from inside the memory card and these can be a combination of graphics, text, image, video and audio commands. Complete list of commands available for the scripting program is listed in a separate document titled:

"GOLDELOX-SGC-COMMANDS-SIS.pdf"

5.3 Auto-Run Card Script Program

The GOLDELOX-SGC embedded in the μLCD-144-G2(SGC) module has a feature that will auto run a preloaded script program, on the uSD/uSDHC memory card, on power-up. If the SWITCH input (pin 6) is connected to GND (on power-up) and if there is a script program present in the memory card then the device will auto run the script program. This is a useful feature for those stand alone applications where the device does not require a host controller to play a slide show of images, video clips, etc.

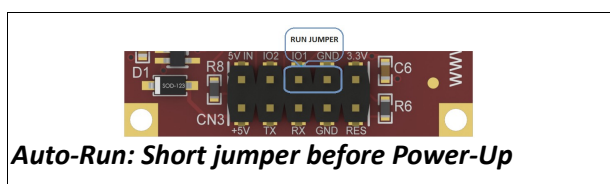

6. Programming - System Updates

The GOLDELOX-SGC processor on the μLCD-144-G2(SGC) module can be re-programmed with the latest PmmC configuration for updates and future proofing. The chip-level configuration is available as a PmmC (Personality-module-micro-Code) file and the programming must be performed over the serial interface. All of the high level software interface commands are part of the PmmC configuration file so please check regularly for the latest updates and enhancements.

It is recommended that the μLCD module be socketed on the application board so that it can be easily removed for PmmC programming.

The PmmC file is programmed into the device with the aid of **"PmmC Loader"**, a PC based software tool. To provide a link between the PC and the μLCD module, a USB to Serial converter is required. A range of custom made micro-USB devices such as the uUSB-MB5 and the uUSB-CE5 are available from 4D Systems.

For further details refer to 'Section 9: Development and Support Tools'.

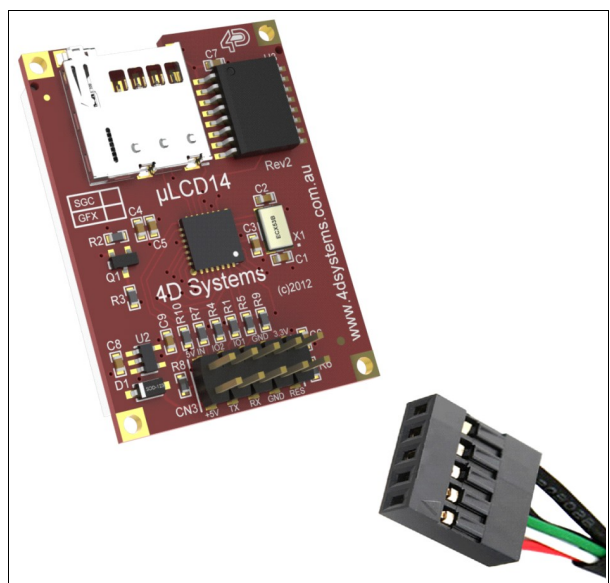

7. LCD Screen Precautions

- Avoid having a White Background. The more pixels that are lit up, the more the display module will consume current. A full white screen will have the highest power consumption.
- Avoid displaying objects or text on White Backgrounds. This will cause a smearing effect which is inherent to all LCD displays. Instead try a shaded mixed colour as the background or better still a black background. Ideally have mixed coloured objects/text/icons on a black background.
- Avoid having to display the same image/object on the screen for lengthy periods of time. This will cause a burn-in which is a common problem with all types of display technologies. Blank the screen after a while or dim it very low by adjusting the contrast. Better still; implement a screen saver feature.
- The display can be easily scratched. The soft polarisation film on the glass surface may be damaged if rubbed by hard objects. Handle with care to avoid scratching the display.
- Moisture and water can damage the display. Moisture on the surface of a powered display will cause the electrodes to corrode. Wipe off any moisture gently or let the display dry before usage.
- Dirt from fingerprint oil and fat can easily stain the surface of the display. Gently wipe off any stains with a soft lint-free cloth.
- The performance of the display will degrade under high temperature and humidity. Avoid such conditions when storing.
- Displays are susceptible to mechanical shock and any force exerted on the module may result in deformed zebra strips and cracks.
- Always use the mounting holes on the module's printed circuit board to mount the display.

8. Mechanical Dimensions

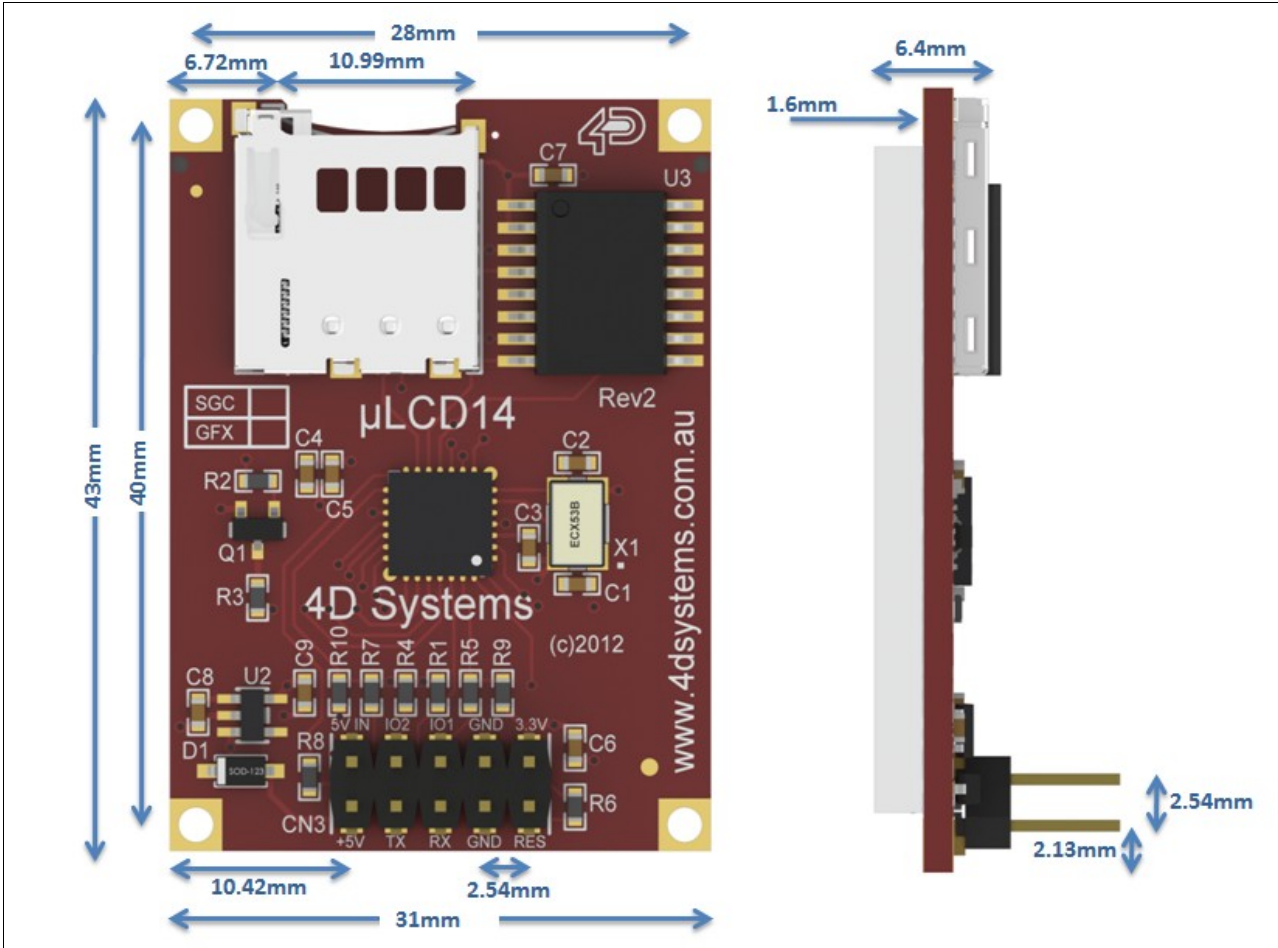

9. Development and Support Tools

9.1 PmmC Loader – Software Programming Tool

The ‘PmmC Loader’ is a free software tool for Windows based PC platforms. Use this tool to program the latest PmmC file into the GOLDELOX-SGC chip embedded in the µLCD module. It is available for download from the 4D Systems website, www.4dsystems.com.au

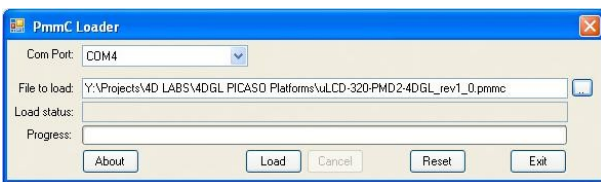

9.2 microUSB – Hardware Programming Tool

The micro-USB module is a USB to Serial bridge adaptor that provides a convenient physical link between the PC and the µLCD module. A range of custom made micro-USB devices such as the 4D Programming Cable, uUSB-MB5 and the uUSB-CE5 are available from 4D Systems (must be purchased separately). The micro-USB module is an essential tool for PmmC programing as well as for using available software tools to test and customise the µLCD module.

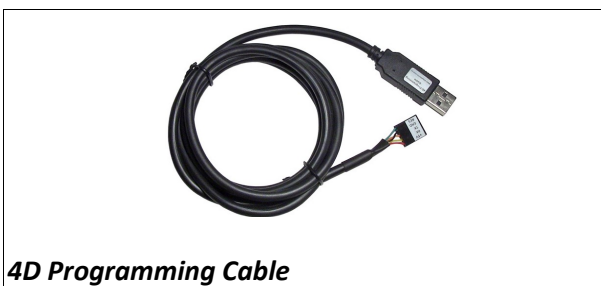
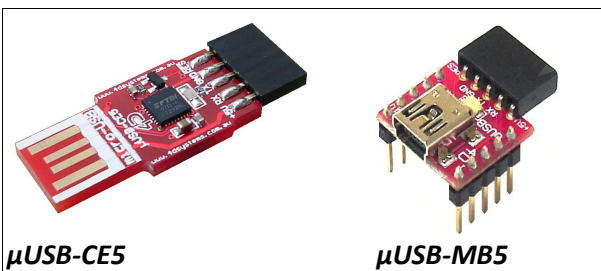

9.3 Display Initialisation Setup Personality (DISP) – Software Programming Tool

DISP is a free software tool for Windows based PC platforms. Use this tool to:-

- Configure the GOLDELOX-SGC chip to work with a specific display (no configuration is required for the µLCD-144-G2(SGC)).
- Modify the way the chip initially sets up the display, e.g. screen saver, brightness, etc.
- Construct the splash screens.
- Replace or modify the embedded fonts.

It is available for download from the 4D Systems website, www.4dsystems.com.au.

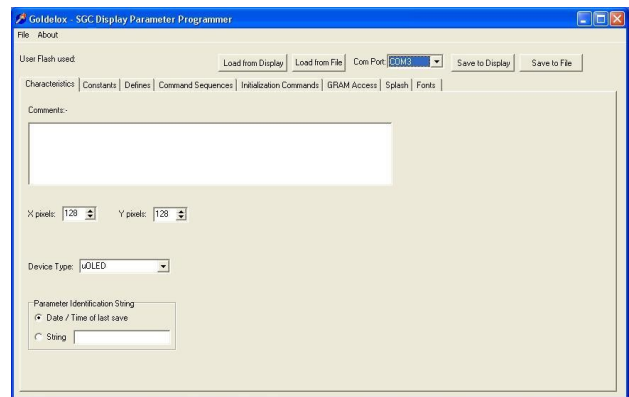

9.4 FONT Tool – Software Tool

Font-Tool is a free software utility for Windows based PC platforms. This tool can be used to assist in the conversion of standard Windows fonts (including True Type) into the bitmap fonts used by the GOLDELOX-SGC chip.

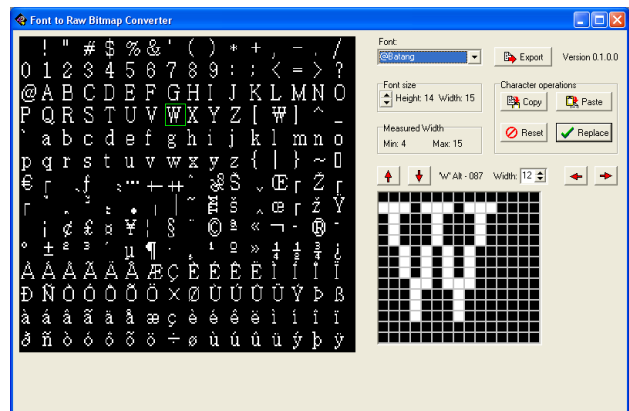

It is available for download from the 4D Systems website, www.4dsystems.com.au.

Disclaimer: Windows fonts may be protected by copyright laws. This software is provided for experimental purposes only.

9.5 Graphics Composer – Software Tool

The Graphics Composer is a free software tool for Windows. This software tool is an aid to composing a slide show of images, animations and movie-clips (multi-media objects) which can then be downloaded into the microSD/microSDHC memory card that is supported by the µLCD-144-G2(SGC). The host simply sends commands to the µLCD to display the multimedia objects.

It is available for download from the 4D Systems website, www.4dsystems.com.au

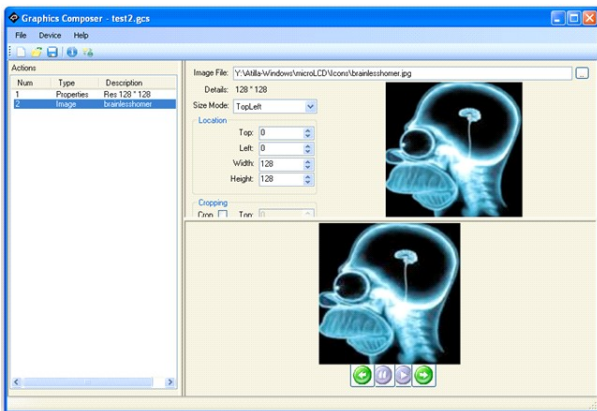

9.6 FAT Controller – Software Test Tool

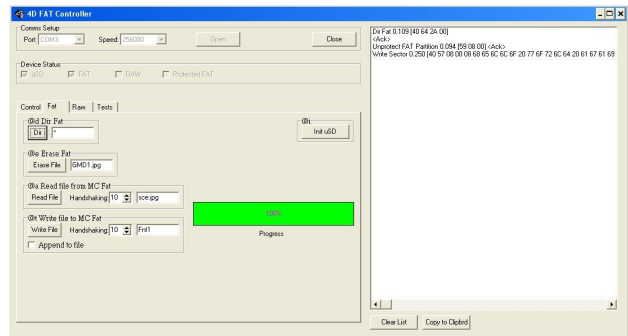

The 4D FAT Controller is a free software tool to test all of the functionality of the GOLDELOX-DOS, GOLDELOX-SGC and the PICASO-SGC devices and their respective modules. It is useful in learning about how to communicate with the chips and the modules. For the GOLDELOX-SGC and the PICASO-SGC it can also simulate most of the operation of the device and assist in the creation of simple scripts, either simulating the execution of those scripts and / or downloading them into a USD/uSDHC card for execution on the display.

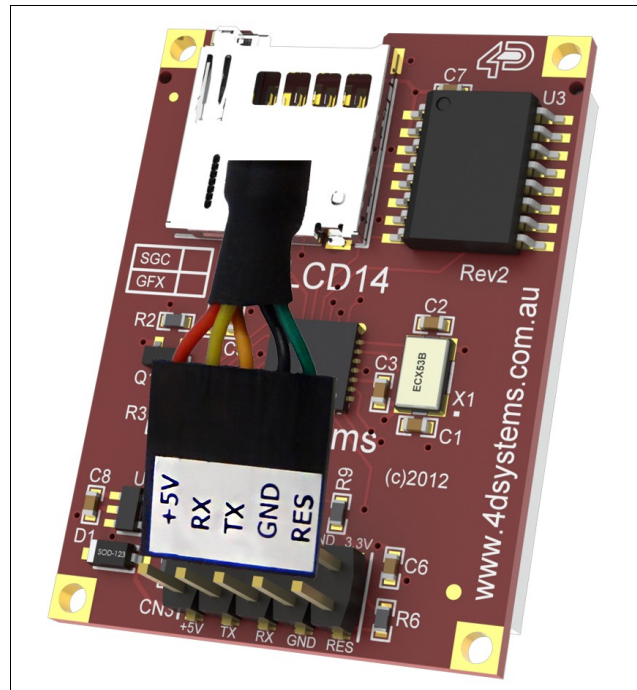

11. Specifications and Ratings

Absolute Maximum Ratings	
Operating ambient temperature	-15°C to +65°C
Storage temperature	-30°C +80°C
Voltage on any digital input pin with respect to GND	-0.3V to 6.0V
Voltage on SWITCH pin with respect to GND	-0.3V to 6.0V
Voltage on Vin with respect to GND	-0.3V to 6.0V
Maximum current out of GND pin	300mA
Maximum current into Vin pin	250mA
Maximum output current sunk/sourced by any pin	4.0mA
Total power dissipation	1.0W

NOTE: Stresses above those listed here may cause permanent damage to the device. This is a stress rating only and functional operation of the device at those or any other conditions above those indicated in the recommended operation listings of this specification is not implied. Exposure to maximum rating conditions for extended periods may affect device reliability.

Recommended Operating Conditions					
Parameter	Conditions	Min	Typ	Max	Units
Supply Voltage (Vin)		4.0	5.0	5.5	V
Operating Temperature		-10	--	60	°C
Input Low Voltage	RX pin	GND	--	0.8	V
Input High Voltage	RX pin	2.0	3.3	5.0	V
Reset Pulse	External Open Collector	2.0	--	--	μs
Operational Delay	Power-Up or External Reset	1000	--	--	ms

Global Characteristics based on Operating Conditions					
Parameter	Conditions	Min	Typ	Max	Units
Supply Current (Iin)	Vin = 5.0V	14	40	120	mA
Low Power Current (Iin)	Vin = 5.0V, Contrast = 0	300	500	--	uA
Output Low Voltage (VOL)	TX, IO2 pins, IOL = 3.4mA	--	--	0.4	V
Output High Voltage (VOH)	TX, IO2 pins, IOL = -2.0mA	2.4	--	3.3	V
A/D Converter Resolution	IO1 pin	--	8	10	bits
Capacitive Loading	All pins	--	--	50	pF
Flash Memory Endurance	PmmC Programming	--	1000	--	E/W

Optical Characteristics							
Parameter	Condition	Temp.	Min	Typ	Max	Unit	
Luminance	V _{in} = 5.0V, I _f = 20mA	--	--	250	--	Cd/m ²	
Response Time	Rise Time(Tr)	-10°C	--	--	--	msec	
	Decay Time(Td)		--	--	--		
	Rise Time(Tr)	25°C	--	--	240		
	Decay Time(Td)		--	--	240		
	Rise Time(Tr)	60°C	--	--	--		
	Decay Time(Td)		--	--	--		
Viewing Angle	θ	25°C	ψ = 0°	--	--	30	Deg
			ψ = 90°	--	--	30	
			ψ = 180°	--	--	30	
			ψ = 270°	--	--	30	
Contrast Ratio	CR	θ = ψ = 0°	25°C	300	450	--	--

Ordering Information
<p>Order Code: μLCD-144-G2(SGC)</p> <p>Package: 150mm x 95mm (ZIF Bag dimensions).</p> <p>Packaging: Module sealed in antistatic padded ZIF bag.</p>

Proprietary Information

The information contained in this document is the property of 4D Systems Pty. Ltd. and may be the subject of patents pending or granted, and must not be copied or disclosed without prior written permission.

4D Systems endeavours to ensure that the information in this document is correct and fairly stated but does not accept liability for any error or omission. The development of 4D Systems products and services is continuous and published information may not be up to date. It is important to check the current position with 4D Systems. 4D Systems reserves the right to modify, update or make changes to Specifications or written material without prior notice at any time.

All trademarks belong to their respective owners and are recognised and acknowledged.

Disclaimer of Warranties & Limitation of Liability

4D Systems makes no warranty, either express or implied with respect to any product, and specifically disclaims all other warranties, including, without limitation, warranties for merchantability, non-infringement and fitness for any particular purpose.

Information contained in this publication regarding device applications and the like is provided only for your convenience and may be superseded by updates. It is your responsibility to ensure that your application meets with your specifications.

In no event shall 4D Systems be liable to the buyer or to any third party for any indirect, incidental, special, consequential, punitive or exemplary damages (including without limitation lost profits, lost savings, or loss of business opportunity) arising out of or relating to any product or service provided or to be provided by 4D Systems, or the use or inability to use the same, even if 4D Systems has been advised of the possibility of such damages.

4D Systems products are not fault tolerant nor designed, manufactured or intended for use or resale as on line control equipment in hazardous environments requiring fail – safe performance, such as in the operation of nuclear facilities, aircraft navigation or communication systems, air traffic control, direct life support machines or weapons systems in which the failure of the product could lead directly to death, personal injury or severe physical or environmental damage ('High Risk Activities'). 4D Systems and its suppliers specifically disclaim any expressed or implied warranty of fitness for High Risk Activities.

Use of 4D Systems' products and devices in 'High Risk Activities' and in any other application is entirely at the buyer's risk, and the buyer agrees to defend, indemnify and hold harmless 4D Systems from any and all damages, claims, suits, or expenses resulting from such use. No licenses are conveyed, implicitly or otherwise, under any 4D Systems intellectual property rights.

Contact Information

For Technical Support : support@4dsystems.com.au

For Sales Support : sales@4dsystems.com.au

Website : www.4dsystems.com.au

Copyright 4D Systems Pty. Ltd. 2000-2012.